

LVHT 51 M 400 G3-B4

Laser Diffuse Sensor

- Large detection range
- Two switching points definable - window function
- Foreground and background suppression
- Teach key + remote teach with key-lock function
- Red light laser with automatic adjustment of the transmitting power
- Robust metal casing
- High protection class

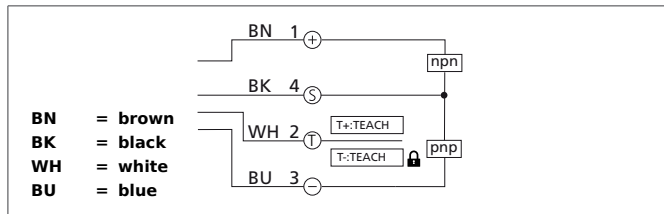

Safety instructions

Inproper use may result in hazardous radiation exposure. Pay attention to accident prevention rules and laser class. The instruments are not to be used for safety applications, in particular applications in which safety of persons depends on proper operation of the instruments. These instruments shall exclusively be used by qualified personnel.

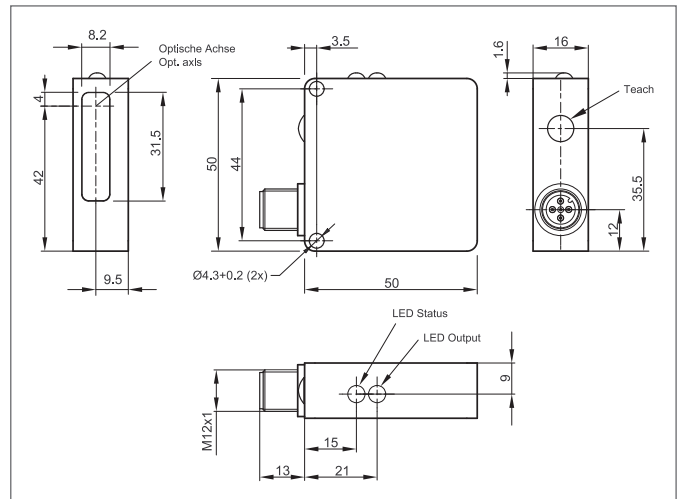

TECHNICAL INFORMATION (typ.)		+20°C, 24V DC
Operating principle		Diffuse reflective sensor
Evaluation		digital
Size		50 x 50 x 16 mm (Dimensions)
Design		cuboid design
Emitted light		Red light laser, 650 nm
Laser class		1 (IEC 60825-1)
Service voltage		10 ... 30 V DC
Internal power consumption		60 mA, (24 V DC)
Diameter of light spot		Ø 2 mm
Operating distance		50 ... 400 mm
Sensitivity adjustment		Teach key + remote teach
Switching output		Push pull, 150 mA, NO/NC, switchable
Switching hysteresis		0,1 %
Display		LED: green - operation, yellow - outputs
Voltage drop		2,0 V
Switching frequency		100 Hz
Reproducibility		0,5%
Ambient temperature		0 ... +50 °C
Ambient light immunity		5 kLx
Insulation voltage endurance		500 V
Protection class		IP 67
Protection degree		III, operation on protective low voltage
Casing material		Aluminium black anodized

LVHT 51 M 400 G3-B4

Laser Diffuse Sensor



TECHNICAL INFORMATION (typ.)

+20°C, 24V DC

Material	polymethyl methacrylate (Window)
Connection	Connector, M12, 4-poled
Connecting cable	VK ...